

Technical brochure

Solenoid valves

Type EVR 2 → 40 NC/ NO

New EVR 6 with Steel cover design

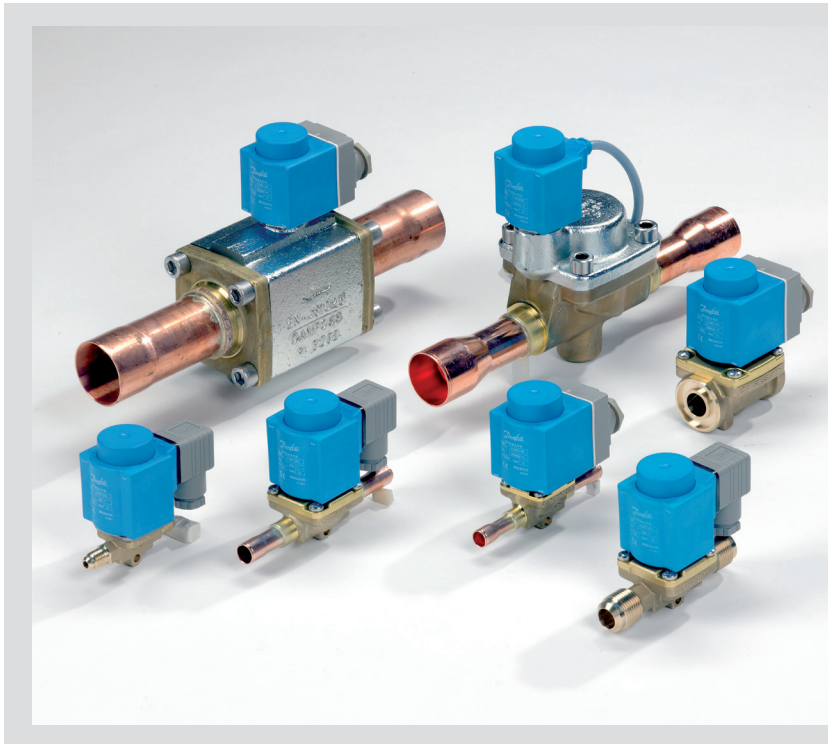

EVR is a direct or servo operated solenoid valve for liquid, suction, and hot gas lines with fluorinated refrigerants.

EVR valves are supplied complete or as separate components, i.e. valve body, coil and flanges, if required, can be ordered separately.

Features

- Complete range of solenoid valves for refrigeration, freezing and air conditioning plant
- Supplied both normally closed (NC) and normally open (NO) with de-energized coil
- Wide choice of coils for a.c. and d.c.
- Suitable for all fluorinated refrigerants
- Designed for media temperatures up to 105°C
- MOPD up to 25 bar with 12 W coil
- Flare connections up to 5/8 in.
- Solder connections up to 2 1/8 in.
- Extended ends for soldering make installation easy. It is not necessary to dismantle the valve when soldering in.
- EVR are also available with flange connections

Approvals

DnV, Det norske Veritas, Norge

Pressure Equipment Directive (PED) 97/23/EC

The Low Voltage Directive (LVD) 73/23/EC with amendments EN 60730-2-8

Polski Rejestr Statków, Polen

MRS, Maritime Register of Shipping, Russia

Versions with UL approval can be supplied to order.

Solenoid valves type EVR 2 → 40 – NC / NO New EVR 6 Steel cover design

Technical data

Refrigerants
CFC, HCFC, HFC

Ambient temperature and enclosure for coil.

See "Coils for solenoid valves", DKRCC.PD.B50.A.02

Temperature of medium
-40 → +105°C with 10 W or 12 W coil.
Max. 130°C during defrosting.

Type	Opening differential pressure with standard coil Δp bar				Temperature of medium °C	Max. working pressure PB bar	k_v value ¹⁾ m ³ /h
	Min.	Max. (= MOPD) liquid ²⁾					
		10 W a. c.	12 W a. c.	20 W d. c.			
EVR 2	0.0	25		18	-40 → 105	45.2	0.16
EVR 3	0.0	21	25	18	-40 → 105	45.2	0.27
EVR 6	0.05	21	25	18	-40 → 105	45.2	0.8
EVR 6 NO	0.05	21	21	21	-40 → 105	45.2	0.8
EVR 10	0.05	21	25	18	-40 → 105	35	1.9
EVR 10 NO	0.05	21	21	21	-40 → 105	35	1.9
EVR 15	0.05	21	25	18	-40 → 105	32	2.6
EVR 15 NO	0.05	21	21	21	-40 → 105	32	2.6
EVR 20 (a.c.)	0.05	21	25	13	-40 → 105	32	5.0
EVR 20 (d.c.)	0.05			16	-40 → 105	32	5.0
EVR 20 NO	0.05	19	19	19	-40 → 105	32	5.0
EVR 22	0.05	21	25	13	-40 → 105	32	6.0
EVR 22 NO	0.05	19	19	19	-40 → 105	32	6.0
EVR 25 ³⁾	0.20	21	25	18	-40 → 105	32	10.0
EVR 32 ³⁾	0.20	21	25	18	-40 → 105	32	16.0
EVR 40 ³⁾	0.20	21	25	18	-40 → 105	32	25.0

¹⁾ The k_v value is the water flow in m³/h at a pressure drop across valve of 1 bar, $\rho = 1000$ kg/m³.

²⁾ MOPD for media in gas form is approx. 1 bar greater.

³⁾ Min. diff. pressure 0.07 bar is needed to stay open.

Type	Rated capacity kW											
	Liquid				Suction vapour				Hot gas			
	R22	R134a	R404A/R507	R407C	R22	R134a	R404A/R507	R407C	R22	R134a	R404A/R507	R407C
EVR 2	3.20	2.90	2.20	3.01					1.50	1.20	1.20	1.46
EVR 3	5.40	5.00	3.80	5.08					2.50	2.00	2.00	2.43
EVR 6	16.10	14.80	11.20	15.13	1.80	1.30	1.60	1.66	7.40	5.90	6.00	7.18
EVR 10	38.20	35.30	26.70	35.91	4.30	3.10	3.90	3.96	17.50	13.90	14.30	16.98
EVR 15	52.30	48.30	36.50	49.16	5.90	4.20	5.30	5.43	24.00	19.00	19.60	23.28
EVR 20	101.00	92.80	70.30	94.94	11.40	8.10	10.20	10.49	46.20	36.60	37.70	44.81
EVR 22	121.00	111.00	84.30	113.74	13.70	9.70	12.20	12.60	55.40	43.90	45.20	53.74
EVR 25	201.00	186.00	141.00	188.94	22.80	16.30	20.40	20.98	92.30	73.20	75.30	89.53
EVR 32	322.00	297.00	225.00	302.68	36.50	26.10	32.60	33.58	148.00	117.00	120.00	143.56
EVR 40	503.00	464.00	351.00	472.82	57.00	40.80	51.00	52.44	231.00	183.00	188.00	224.07

Rated liquid and suction vapour capacity is based on
evaporating temperature $t_e = -10^\circ\text{C}$,
liquid temperature ahead of valve $t_l = +25^\circ\text{C}$,
pressure drop in valve $\Delta p = 0.15$ bar.

Rated hot gas capacity is based on
condensing temperature $t_c = +40^\circ\text{C}$,
pressure drop across valve $\Delta p = 0.8$ bar,
hot gas temperature $t_h = +65^\circ\text{C}$,
and subcooling of refrigerant $\Delta t_{\text{sub}} = 4$ K.

Solenoid valves type EVR 2 → 40 – NC / NO New EVR 6 Steel cover design

Ordering

Complete valves

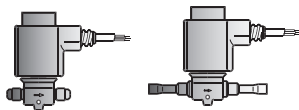

Normally closed (NC) with a.c. coil ¹⁾

Type	Connection		Code no.		
			Valve body + 10 W a. c. coil with 1 m cable		
	in.	mm	Flare ²⁾	Solder ODF	
			in./mm	in.	mm
EVR 3	1/4	6	032F8109	032F2042	032F2052
EVR 6	3/8	10	032F8073	032F2082	032F2092
EVR 10	1/2	12	032F8091	032F2122	032F2132
EVR 15	5/8	16	032F8102	032F2192	032F2192

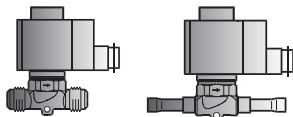

Type	Connection		Code no.		
			Valve body + 10 W a. c. coil with terminal box		
	in.	mm	Flare ²⁾	Solder ODF	
			in./mm	in.	mm
EVR 3	1/4	6	032F8110	032F2043	032F2053
EVR 6	3/8	10	032F8074	032F2083	032F2093
EVR 10	1/2	12	032F8092	032F2123	032F2133
EVR 15	5/8	16	032F8103	032F2193	032F2193
EVR 20	7/8	22		032F2243	032F2243

¹⁾ Please specify code no., voltage and frequency. Voltage and frequency can also be given in the form of an appendix number, see table "Appendix numbers".

²⁾ Supplied without flare nuts.

Separate flare nuts:

1/4 in. or 6 mm, code no. **011L1101**

3/8 in. or 10 mm, code no. **011L1135**

1/2 in. or 12 mm, code no. **011L1103**

5/8 in. or 16 mm, code no. **011L1167**

³⁾ Can only be used with DIN plug

Solenoid valves type EVR 2 → 40 – NC / NO New EVR 6 Steel cover design

Ordering (continued)

Components
Flare and solder connections

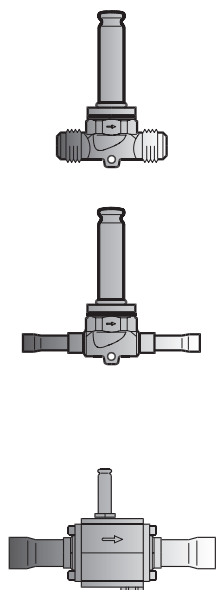

Separate valve bodies, normally closed (NC)

Type	Required coil type	Connection		Code no. Valve body without coil					
				Flare ¹⁾		Solder ODF			
		in.	mm	in./mm	in.	mm	With manual operation	Without manual operation	
EVR 2	a.c.	1/4	6	032F8056	032F1201	032F1202			
EVR 3	a.c./d.c.	1/4	6	032F8107	032F1206	032F1207			
EVR 6		3/8	10	032F8116	032F1204	032F1208			
		3/8	10	032F8072	032F1212	032F1213			
EVR 10		1/2	12	032F8079	032F1209	032F1236			
		1/2	12	032F8095	032F1217	032F1218			
EVR 15		5/8	16	032F8098	032F1214	032F1214			
		5/8	16	032F8101	032F1228	032F1228			
		5/8	16	032F8100 ²⁾			032F1227		
EVR 20		a.c.	7/8	22		032F1240	032F1240		
			7/8	22				032F1254	
	d.c.	1 1/8	28		032F1244	032F1245			
		7/8	22		032F1264	032F1264			
EVR 22	a.c.	1 3/8	35		032F3267	032F3267			
EVR 25	a.c./d.c.	1 1/8					032F2200	032F2201	
			28				032F2205	032F2206	
		1 3/8	35				032F2207	032F2208	
EVR 32		1 3/8	35				042H1105	042H1106	
		1 5/8					042H1103	042H1104	
EVR 40			42				042H1107	042H1108	
		1 5/8					042H1109	042H1110	
			42				042H1113	042H1114	
			2 1/8	54				042H1111	042H1112

Separate valve bodies, normally open (NO) ³⁾

Type	Required coil type	Connection		Code no. Valve body without coil ³⁾			
				Flare ¹⁾		Solder ODF	
		in.	mm	in.	mm	in.	mm
EVR 6	a.c./d.c.	3/8	10	032F8085	032F8085	032F1290	032F1295
EVR 10		1/2	12	032F8090	032F8090	032F1291	032F1296
EVR 15		5/8	16	032F8099	032F8099	032F1299	032F1299
		7/8	22			032F3270	032F3270
EVR 20		7/8	22			032F1260	032F1260
		1 1/8	28			032F1269	032F1279
EVR 22	a.c.	1 3/8	35			032F3268	032F3268

¹⁾ Valve bodies are supplied without flare nuts.

Separate flare nuts:

1/4 in. or 6 mm, code no. **011L1101**

3/8 in. or 10 mm, code no. **011L1135**

1/2 in. or 12 mm, code no. **011L1103**

5/8 in. or 16 mm, code no. **011L1167**

²⁾ With manual operation.

³⁾ The normal range of coils can be used for the NO valves, with the exception of the double frequency versions of 110 V, 50/60 Hz and 220 V, 50/60 Hz.

Coils

See "Coils for solenoid valves", DKRCC.PD.BS0.A.02

Solenoid valves type EVR 2 → 40 – NC / NO New EVR 6 Steel cover design

Ordering (continued)

Components
Flare and solder connections

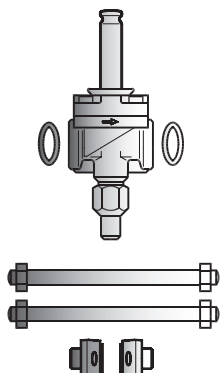

Separate valve bodies, normally closed (NC)

Type	Require coil type	Connection	Code no. Valve body + gaskets +bolts; without coil and flanges	
			Without manual operation	Without manual operation
EVR 15	a.c./d.c.	Flanges	032F1234	032F1224
EVR 20	a.c.		032F1253	032F1243
	d.c.		032F1273	032F1263

Coils

See "Coils for solenoid valves", RD.3J.E2.02.

Flange sets

Valve type	Connection		Code no.		
			Solder		Weid
	in.	mm	in.	mm	in.
EVR 15	1/2				027N1115
	5/8	16	027L1117	027L1116	
	3/4				027N1120
	7/8	22	027L1123	027L1122	
EVR 20	3/4				027N1220
	7/8	22	027L1223	027L1222	
	1				027N1225
	1 1/8	28	027L1229	027L1228	

Example

EVR 15 without manual operation,
code no. **032F1224**

+ 1/2 in. weld flange set,
code no. **027N1115**

+ coil with terminal box, 220 V, 50 Hz,
code no. **018F6701**
(See "Coils for solenoid valves",
DKRCC.PD.BS0.A.02)

Accessories

Description	Code no.
Mounting bracket for EVR 2, 3, 6 and 10	032F0197
Strainer FA for direct mounting	See "FA"

Solenoid valves type EVR 2 → 40 – NC / NO New EVR 6 Steel cover design
Capacity
Liquid capacity Q_e kW
R22

Type	Liquid capacity Q_e kW at pressure drop across valve Δp bar				
	0.1	0.2	0.3	0.4	0.5
EVR 2	2.6	3.7	4.6	5.3	5.9
EVR 3	4.5	6.3	7.7	8.9	9.9
EVR 6	13.1	18.6	22.8	26.3	29.4
EVR 10	31.4	44.1	54.2	62.5	69.9
EVR 15	42.7	60.3	74.1	85.5	95.7
EVR 20	82.2	116.0	143.0	165.0	184.0
EVR 22	99.0	139.0	171.0	197.0	220.0
EVR 25	165.0	232.0	285.0	329.0	368.0
EVR 32	263.0	372.0	455.0	526.0	588.0
EVR 40	411.0	581.0	712.0	822.0	919.0

Liquid capacity Q_e kW
R134a

Type	Liquid capacity Q_e kW at pressure drop across valve Δp bar				
	0.1	0.2	0.3	0.4	0.5
EVR 2	2.4	3.4	4.2	4.9	5.4
EVR 3	4.1	5.8	7.1	8.2	9.1
EVR 6	12.1	17.2	21.0	24.3	27.1
EVR 10	28.8	40.7	49.9	57.6	64.4
EVR 15	39.4	55.7	68.3	78.8	88.1
EVR 20	75.8	107.0	131.0	152.0	170.0
EVR 22	90.9	129.0	158.0	182.0	203.0
EVR 25	152.0	214.0	263.0	303.0	339.0
EVR 32	243.0	343.0	420.0	485.0	542.0
EVR 40	379.0	536.0	656.0	758.0	847.0

Liquid capacity Q_e kW
R404A/R507

Type	Liquid capacity Q_e kW at pressure drop across valve Δp bar				
	0.1	0.2	0.3	0.4	0.5
EVR 2	1.8	2.6	3.2	3.7	4.1
EVR 3	3.1	4.4	5.4	6.2	6.9
EVR 6	9.2	13.0	15.9	18.4	20.5
EVR 10	21.8	30.8	37.8	43.6	48.8
EVR 15	29.8	42.2	51.7	59.6	66.8
EVR 20	57.4	81.1	99.4	115.0	128.0
EVR 22	68.9	97.4	119.0	138.0	169.0
EVR 25	115.0	162.0	199.0	230.0	257.0
EVR 32	184.0	260.0	318.0	367.0	411.0
EVR 40	287.0	406.0	497.0	574.0	642.0

Capacities are based on
 liquid temperature $t_l = +25^\circ\text{C}$ ahead of valve,
 evaporating temperature $t_e = -10^\circ\text{C}$,
 superheat 0 K.

Correction factors

When sizing valves, the plant capacity must be multiplied by a correction factor depending on liquid temperature t_l ahead of valve/evaporator. When the corrected capacity is known, the selection can be made from the table.

Correction factors for liquid temperature t_l

t_l °C	-10	0	10	15	20	25	30	35	40	45	50
R22	0.76	0.82	0.88	0.92	0.96	1.0	1.05	1.10	1.16	1.22	1.30
R134a	0.73	0.79	0.86	0.90	0.95	1.0	1.06	1.12	1.19	1.27	1.37
R404A/R507	0.65	0.72	0.81	0.86	0.93	1.0	1.09	1.20	1.33	1.51	1.74

Solenoid valves type EVR 2 → 40 – NC / NO New EVR 6 Steel cover design

Capacity (continued)

R407C

Liquid capacity Q_e kW

Type	Liquid capacity Q_e kW at pressure drop across valve Δp bar				
	0.1	0.2	0.3	0.4	0.5
EVR 2	2.4	3.4	4.3	5.0	5.3
EVR 3	4.2	5.9	7.2	8.4	9.3
EVR 6	12.3	17.5	21.4	24.7	27.6
EVR 10	29.5	41.5	50.9	58.7	65.7
EVR 15	40.1	56.7	69.7	80.4	90.0
EVR 20	77.0	109.0	134.0	155.0	172.0
EVR 22	93.1	130.0	161.0	185.2	207.0
EVR 25	155.0	218.0	268.0	309.0	346.0
EVR 32	247.0	350.0	428.0	494.0	553.0
EVR 40	386.0	546.0	669.0	773.0	864.0

Capacities are based on liquid temperature $t_l = +25^\circ\text{C}$ ahead of valve, evaporating temperature $t_e = -10^\circ\text{C}$, and superheat 0 K.

Correction factors

When sizing valves, the plant capacity must be multiplied by a correction factor depending on liquid temperature t_l ahead of valve/evaporator. When the corrected capacity is known, the selection can be made from the table.

Correction factors based on liquid temperature t_l

t_l °C	-10	0	10	15	20	25	30	35	40	45	50
R407C	0.71	0.78	0.85	0.89	0.94	1.0	1.06	1.14	1.23	1.33	1.46

Suction vapour capacity Q_e

R22

Type	Pressure drop Δp bar	Suction vapour capacity Q_e kW at evaporating temperature t_e °C					
		-40	-30	-20	-10	0	+10
EVR 6	0.1	0.73	0.94	1.2	1.5	1.8	2.1
	0.15	0.87	1.1	1.4	1.8	2.2	2.6
	0.2	0.98	1.3	1.6	2.0	2.5	3.0
EVR 10	0.1	1.7	2.2	2.9	3.5	4.3	5.1
	0.15	2.1	2.7	3.4	4.3	5.2	6.2
	0.2	2.3	3.1	3.9	4.8	6.0	7.1
EVR 15	0.1	2.3	3.1	4.0	4.8	5.8	6.9
	0.15	2.8	3.7	4.7	5.9	7.1	8.5
	0.2	3.2	4.2	5.3	6.6	8.2	9.8
EVR 20	0.1	4.6	5.9	7.6	9.3	11.2	13.3
	0.15	5.4	7.1	9.1	11.4	13.9	16.7
	0.2	6.1	8.1	10.3	12.7	15.9	18.8
EVR 22	0.1	5.5	7.1	9.1	11.2	13.4	16.0
	0.15	6.5	8.5	10.7	13.7	16.4	20.0
	0.2	7.3	9.7	12.3	15.2	19.0	22.6
EVR 25	0.1	9.1	11.8	15.2	18.6	22.4	26.6
	0.15	10.9	14.2	17.9	22.8	27.4	32.6
	0.2	12.2	16.1	20.4	25.3	31.7	37.6
EVR 32	0.1	14.6	18.9	24.3	29.8	35.8	42.6
	0.15	17.4	22.7	28.8	36.5	43.8	52.2
	0.2	19.6	25.7	32.6	40.5	50.7	60.2
EVR 40	0.1	22.8	29.5	38.1	46.5	56.0	66.5
	0.15	27.2	35.4	45.0	57.0	68.6	81.5
	0.2	30.5	40.2	51.0	63.3	79.2	94.0

Capacities are based on liquid temperature $t_l = +25^\circ\text{C}$ ahead of evaporator. The table values refer to the evaporator capacity and are given as a function of evaporating temperature t_e and pressure drop Δp across valve. Capacities are based on dry, saturated vapour ahead of valve. During operation with superheated vapour ahead of valve, the capacities are reduced by 4% for each 10 K superheat.

Correction factors

When sizing valves, the evaporator capacity must be multiplied by a correction factor depending on liquid temperature t_l ahead of expansion valve.

When the corrected capacity is known, the selection can be made from the table.

Correction factors for liquid temperature t_l

t_l °C	-10	0	10	15	20	25	30	35	40	45	50
R22	0.76	0.82	0.88	0.92	0.96	1.0	1.05	1.10	1.16	1.22	1.30

Solenoid valves type EVR 2 → 40 – NC / NO New EVR 6 Steel cover design
Capacity
(continued)

Suction vapour capacity Q_e
R134a

Type	Pressure drop across valve Δp bar	Suction vapour capacity Q_e kW at evaporating temperature t_e °C					
		-40	-30	-20	-10	0	+10
EVR 6	0.1	0.46	0.73	0.84	1.1	1.4	1.7
	0.15	0.53	0.87	1.0	1.3	1.7	2.0
	0.2	0.58	0.98	1.1	1.5	1.9	2.4
EVR 10	0.1	1.1	1.7	2.0	2.6	3.3	4.0
	0.15	1.3	2.1	2.4	3.1	4.0	4.9
	0.2	1.4	2.3	2.7	3.5	4.5	5.7
EVR 15	0.1	1.5	2.3	2.7	3.6	4.5	5.5
	0.15	1.7	2.8	3.3	4.2	5.5	6.7
	0.2	1.9	3.2	3.7	4.8	6.1	7.8
EVR 20	0.1	2.9	4.6	5.3	7.0	8.6	10.6
	0.15	3.3	5.4	6.3	8.1	10.6	13.0
	0.2	3.7	6.1	7.1	9.3	11.7	15.0
EVR 22	0.1	3.4	5.5	6.3	8.3	10.3	12.7
	0.15	4.0	6.5	7.5	9.7	12.7	15.5
	0.2	4.4	7.3	8.5	11.1	14.0	17.9
EVR 25	0.1	5.8	9.1	10.5	13.9	17.2	21.1
	0.15	6.6	10.9	12.5	16.3	21.1	25.9
	0.2	7.3	12.2	14.1	18.5	23.4	29.9
EVR 32	0.1	9.3	14.6	16.8	22.2	27.7	33.8
	0.15	10.6	17.4	20.0	26.1	33.8	41.4
	0.2	11.7	19.6	22.6	29.6	37.4	47.4
EVR 40	0.1	14.5	22.8	26.3	34.8	43.3	52.8
	0.15	16.5	27.2	31.3	40.8	52.8	64.8
	0.2	18.3	30.5	35.3	46.3	58.5	74.8

Suction vapour capacity Q_e kW
R404A/R507

Type	Pressure drop across valve Δp bar	Suction vapour capacity Q_e kW at evaporating temperature t_e °C					
		-40	-30	-20	-10	0	+10
EVR 6	0.1	0.62	0.8	1.1	1.3	1.6	2.0
	0.15	0.73	0.97	1.3	1.6	2.0	2.4
	0.2	0.82	1.1	1.4	1.8	2.3	2.8
EVR 10	0.1	1.5	1.9	2.5	3.2	3.9	4.7
	0.15	1.7	2.3	3.0	3.9	4.8	5.8
	0.2	2.0	2.6	3.4	4.3	5.5	6.7
EVR 15	0.1	2.0	2.6	3.5	4.3	5.3	6.4
	0.15	2.4	3.2	4.1	5.3	6.5	7.9
	0.2	2.7	3.6	4.7	5.9	7.5	9.1
EVR 20	0.1	3.9	5.0	6.7	8.3	10.2	12.3
	0.15	4.6	6.1	7.9	10.2	12.5	15.2
	0.2	5.2	6.9	9.0	11.4	14.4	17.5
EVR 22	0.1	4.6	6.0	8.0	10.0	12.2	14.8
	0.15	5.5	7.3	9.5	12.2	15.0	18.2
	0.2	6.2	8.3	10.8	13.6	17.3	21.0
EVR 25	0.1	7.7	10.1	13.3	16.6	20.4	24.6
	0.15	9.1	12.1	15.8	20.4	25.0	30.3
	0.2	10.3	13.8	18.0	22.7	28.8	35.0
EVR 32	0.1	12.3	16.2	21.3	26.6	32.6	39.4
	0.15	14.6	19.4	25.3	32.6	40.0	48.5
	0.2	16.5	22.0	28.8	36.3	46.1	56.0
EVR 40	0.1	19.3	25.3	33.3	41.5	51.0	61.5
	0.15	22.8	30.3	39.5	51.0	62.5	75.6
	0.2	25.8	34.5	45.0	56.8	72.1	87.5

Capacities are based on liquid temperature $t_l = +25^\circ\text{C}$ ahead of evaporator. The table values refer to the evaporator capacity and are given as a function of evaporating temperature t_e and pressure drop Δp across valve. Capacities are based on dry, saturated vapour ahead of valve. During operation with superheated vapour ahead of valve, the capacities are reduced by 4% for each 10 K superheat.

Correction factors

When sizing valves, the plant capacity must be multiplied by a correction factor depending on liquid temperature t_l ahead of valve/evaporator. When the corrected capacity is known, the selection can be made from the table.

Correction factors based on liquid temperature t_l

t_l °C	-10	0	10	15	20	25	30	35	40	45	50
R134a	0.73	0.79	0.86	0.90	0.95	1.0	1.06	1.12	1.19	1.27	1.37
R404A/R507	0.65	0.72	0.81	0.86	0.93	1.0	1.09	1.20	1.33	1.51	1.74

Capacity
(continued)

Type	Pressure drop across valve Δp bar	Suction vapour capacity Q_e kW at evaporating temperature t_e °C					
		-40	-30	-20	-10	0	+10
EVR 6	0.1	0.61	0.81	1.1	1.4	1.7	2.0
	0.15	0.72	0.95	1.3	1.7	2.1	2.5
	0.2	0.81	1.1	1.4	1.8	2.4	2.9
EVR 10	0.1	1.4	1.9	2.6	3.2	4.0	4.9
	0.15	1.7	2.3	3.0	4.0	4.9	6.0
	0.2	1.9	2.7	3.5	4.4	5.6	6.9
EVR 15	0.1	1.9	2.7	3.6	4.4	5.5	6.7
	0.15	2.3	3.2	4.2	5.4	6.7	8.2
	0.2	2.7	3.6	4.7	6.1	7.7	9.5
EVR 20	0.1	3.8	5.1	6.8	8.6	10.5	12.9
	0.15	4.5	6.1	8.1	10.5	13.1	16.2
	0.2	5.1	7.0	9.2	11.7	14.9	18.2
EVR 22	0.1	4.6	6.1	8.1	10.3	12.6	15.5
	0.15	5.4	7.3	9.5	12.6	15.4	19.4
	0.2	6.1	8.3	11.0	14.0	17.9	21.9
EVR 25	0.1	7.6	10.2	13.5	17.1	21.1	25.8
	0.15	9.1	12.2	15.9	21.0	25.8	31.6
	0.2	10.1	13.9	18.2	23.3	29.8	36.5
EVR 32	0.1	12.1	16.3	21.6	27.4	33.7	41.3
	0.15	14.4	19.5	25.6	33.6	41.2	50.6
	0.2	16.3	22.1	29.0	37.3	47.7	58.4
EVR 40	0.1	18.9	25.4	33.9	42.8	52.6	64.5
	0.15	22.6	30.4	40.1	52.4	64.5	79.1
	0.2	25.3	34.6	45.4	58.2	74.4	91.2

Capacities are based on liquid temperature $t_l = +25^\circ\text{C}$ ahead of evaporator.
 The table values refer to the evaporator capacity and are given as a function of evaporating temperature t_e and pressure drop Δp across valve.
 Capacities are based on dry, saturated vapour ahead of valve.
 During operation with superheated vapour ahead of valve, the capacities are reduced by 4% for each 10 K superheat.

Correction factors

When sizing valves, the evaporator capacity must be multiplied by a correction factor depending on liquid temperature t_l ahead of expansion valve. When the corrected capacity is known, the selection can be made from the table.

Correction factors based on liquid temperature t_l

t_l °C	-10	0	10	15	20	25	30	35	40	45	50
R407C	0.71	0.78	0.85	0.89	0.94	1.0	1.06	1.14	1.23	1.33	1.46

Hot gas defrosting

With hot gas defrosting it is not normally possible to select a valve from condensing temperature t_c and evaporating temperature t_e . This is because the pressure in the evaporator as a rule quickly rises to a value near that of the condensing pressure. It remains at this value until the defrosting is finished. In most cases therefore, the valve will be selected from condensing temperature t_c and pressure drop Δp across the valve, as shown in the example for heat recovery.

Heat recovery

The following is given:
 Refrigerant = R22
 Evaporating temperature $t_e = -30^\circ\text{C}$
 Condensing temperature $t_c = +40^\circ\text{C}$
 Hot gas temperature ahead of valve $t_h = +85^\circ\text{C}$
 Heat recovery condenser yield $Q_h = 8$ kW

The capacity table for 22 with $t_c = +40^\circ\text{C}$ gives the capacity for an EVR 10 as 8.9 kW, when pressure drop Δp is 0.2 bar. The correction factor for $t_e = -30^\circ\text{C}$ is given in the table as 0.94.

The correction for hot gas temperature $t_h = +85^\circ\text{C}$ has been calculated as 4% which corresponds to a factor of 1.04.

Q_h must be corrected with factors found:
 With $\Delta p = 0.2$ bar is
 $Q_h = 8.9 \times 0.94 \times 1.04 = 8.7$ kW.
 With $\Delta p = 0.1$ bar, Q_h becomes only
 $6.3 \times 0.94 \times 1.04 = 6.2$ kW.

An EVR 6 would also be able to give the required capacity, but with Δp at approx. 1 bar. The EVR 6 is therefore too small.

The EVR is so large that it is doubtful whether the necessary Δp of approx. 0.1 bar could be obtained. An EVR 15 would therefore be too large.

Result: An EVR 10 is the correct valve for the given conditions.

Solenoid valves type EVR 2 → 40 – NC / NO New EVR 6 Steel cover design
Capacity
(continued)

 Hot gas capacity Q_h kW

R22

Type	Pressure drop across valve Δp bar	Hot gas capacity Q_h kW				
		Evaporating temp. $t_e = -10^\circ\text{C}$. Hot gas temp. $t_h = t_e + 25^\circ\text{C}$. Subcooling $\Delta t_{\text{sub}} = 4$ K				
		Condensing temperature t_c °C				
		+20	+30	+40	+50	+60
EVR 2	0.1	0.47	0.50	0.53	0.54	0.55
	0.2	0.67	0.71	0.75	0.77	0.78
	0.4	0.96	1.02	1.07	1.10	1.11
	0.8	1.32	1.37	1.48	1.57	1.59
	1.6	1.87	1.99	2.08	2.16	2.19
EVR 3	0.1	0.80	0.85	0.89	0.92	0.93
	0.2	1.14	1.20	1.26	1.30	1.32
	0.4	1.63	1.72	1.80	1.85	1.87
	0.8	2.23	2.31	2.49	2.65	2.68
	1.6	3.15	3.35	3.52	3.64	3.69
EVR 6	0.1	2.4	2.5	2.6	2.7	2.8
	0.2	3.4	3.6	3.7	3.4	3.9
	0.4	4.8	5.1	5.3	5.5	5.6
	0.8	6.6	6.8	7.4	7.9	7.9
	1.6	9.3	9.9	10.4	10.8	10.9
EVR 10	0.1	5.6	6.0	6.3	6.5	6.5
	0.2	8.0	8.5	8.9	9.2	9.3
	0.4	11.4	12.1	12.7	13.0	13.2
	0.8	15.7	16.2	17.5	18.7	18.9
	1.6	22.2	23.6	24.8	25.6	26.0
EVR 15	0.1	7.7	8.2	8.6	8.8	8.9
	0.2	11.0	11.6	12.1	12.5	12.7
	0.4	15.7	16.6	17.3	17.8	18.0
	0.8	21.5	22.2	24.0	25.5	25.9
	1.6	30.3	32.3	33.9	35.0	35.5
EVR 20	0.1	14.8	15.7	16.5	17.0	17.2
	0.2	21.1	22.3	23.4	24.1	24.4
	0.4	30.0	31.9	33.3	34.3	34.7
	0.8	41.3	42.7	46.2	49.1	49.6
	1.6	58.3	62.1	65.2	67.4	68.4
EVR 22	0.1	17.8	18.8	19.7	20.4	20.6
	0.2	25.3	26.8	28.0	28.9	29.3
	0.4	36.1	38.3	40.0	41.2	41.6
	0.8	49.5	51.2	55.4	58.9	59.5
	1.6	70.0	74.5	78.2	80.8	82.0
EVR 25	0.1	29.6	31.4	32.9	34.0	34.4
	0.2	42.1	44.6	46.7	48.2	48.8
	0.4	60.2	63.8	66.6	68.6	69.4
	0.8	82.5	87.9	92.3	98.2	99.2
	1.6	117.0	124.0	130.0	135.0	137.0
EVR 32	0.1	47.4	50.2	52.6	54.4	55.0
	0.2	67.4	71.4	74.7	77.1	78.1
	0.4	96.3	102.0	107.0	110.0	111.0
	0.8	132.0	140.0	148.0	157.0	159.0
	1.6	187.0	199.0	209.0	216.0	219.0
EVR 40	0.1	74.0	78.5	82.3	85.0	86.0
	0.2	105.0	112.0	117.0	121.0	122.0
	0.4	151.0	159.0	167.0	172.0	174.0
	0.8	206.0	222.0	231.0	246.0	248.0
	1.6	291.0	310.0	326.0	337.0	342.0

An increase in hot gas temperature t_h of 10 K, based on $t_h = t_e + 25^\circ\text{C}$, reduces valve capacity approx. 2% and vice versa.

A change in evaporating temperature t_e changes valve capacity; see correction factor table below.

Correction factors

When sizing valves, the table value must be multiplied by a correction factor depending on evaporating temperature t_e .

Correction factors for evaporating temperature t_e

t_e °C	-40	-30	-20	-10	0	+10
R22	0.90	0.94	0.97	1.0	1.03	1.05

Solenoid valves type EVR 2 → 40 – NC / NO New EVR 6 Steel cover design
R134a
Capacity
(continued)

Hot gas capacity Q_h kW

Type	Pressure drop across valve Δp bar	Hot gas capacity Q_h kW				
		Evaporating temp. $t_e = -10^\circ\text{C}$. Hot gas temp. $t_h = t_e + 25^\circ\text{C}$. Subcooling $\Delta t_{\text{sub}} = 4 \text{ K}$				
		Condensing temperature t_c °C				
		+20	+30	+40	+50	+60
EVR 2	0.1	0.38	0.40	0.41	0.42	0.42
	0.2	0.54	0.57	0.59	0.60	0.59
	0.4	0.74	0.82	0.84	0.86	0.85
	0.8	1.06	1.13	1.17	1.23	1.22
	1.6	1.50	1.61	1.67	1.70	1.69
EVR 3	0.1	0.64	0.67	0.70	0.71	0.71
	0.2	0.91	0.96	0.99	1.01	1.00
	0.4	1.26	1.38	1.42	1.44	1.43
	0.8	1.79	1.90	1.98	2.08	2.05
	1.6	2.57	2.72	2.82	2.88	2.86
EVR 6	0.1	1.88	1.99	2.07	2.11	2.09
	0.2	2.69	2.84	2.95	3.00	2.97
	0.4	3.73	4.08	4.22	4.28	4.23
	0.8	5.29	5.62	5.86	6.16	6.08
	1.6	7.61	8.05	8.37	8.52	8.46
EVR 10	0.1	4.5	4.7	4.9	5.0	5.0
	0.2	6.4	6.8	7.0	7.1	7.1
	0.4	8.9	9.7	10.0	10.2	10.1
	0.8	12.6	13.3	13.9	14.6	14.4
	1.6	18.1	19.1	19.9	20.2	20.1
EVR 15	0.1	6.1	6.5	6.7	6.7	6.8
	0.2	8.7	9.2	9.6	9.7	9.7
	0.4	12.1	13.3	13.7	13.9	13.8
	0.8	17.2	18.3	19.0	20.0	19.8
	1.6	24.8	26.2	27.2	27.7	27.5
EVR 20	0.1	11.8	12.5	13.0	13.2	13.1
	0.2	16.8	17.8	18.4	18.7	18.6
	0.4	23.4	25.5	26.4	26.7	26.5
	0.8	33.1	35.1	36.6	38.5	38.0
	1.6	47.6	50.3	52.3	53.3	52.9
EVR 22	0.1	14.1	15.0	15.5	15.8	15.7
	0.2	20.2	21.3	22.1	22.6	22.3
	0.4	28.0	30.6	31.6	32.1	31.7
	0.8	39.7	42.2	43.9	46.2	45.6
	1.6	57.1	60.4	62.8	63.9	63.5
EVR 25	0.1	23.6	24.9	25.9	26.4	26.2
	0.2	33.6	35.5	36.8	37.4	37.1
	0.4	46.6	51.0	52.7	53.4	52.9
	0.8	66.2	70.2	73.2	77.0	76.0
	1.6	95.2	101.0	105.0	107.0	106.0
EVR 32	0.1	37.6	39.8	41.4	42.1	41.8
	0.2	53.8	56.8	58.9	59.8	59.4
	0.4	74.7	81.6	84.3	85.4	84.6
	0.8	106.0	112.0	117.0	123.0	122.0
	1.6	152.0	161.0	167.0	170.0	169.0
EVR 40	0.1	58.8	62.3	64.7	65.8	65.3
	0.2	84.1	88.8	92.1	93.5	92.8
	0.4	117.0	127.0	132.0	134.0	132.0
	0.8	166.0	176.0	183.0	192.0	190.0
	1.6	238.0	252.0	262.0	266.0	265.0

An increase in hot gas temperature t_h of 10 K, based on $t_h = t_e + 25^\circ\text{C}$, reduces valve capacity approx. 2% and vice versa.

A change in evaporating temperature t_e changes valve capacity; see correction factor table below.

Correction factors

When sizing valves, the table value must be multiplied by a correction factor depending on evaporating temperature t_e .

Correction factors for evaporating temperature t_e

t_e °C	-40	-30	-20	-10	0	+10
R134A	0.88	0.92	0.98	1.0	1.04	1.08

Solenoid valves type EVR 2 → 40 – NC / NO New EVR 6 Steel cover design
Capacity
(continued)

 Hot gas capacity Q_h kW

R404A/R507

Type	Pressure drop across valve Δp bar	Hot gas capacity Q_h kW				
		Evaporating temp. $t_e = -10^\circ\text{C}$. Hot gas temp. $t_h = t_e + 25^\circ\text{C}$. Subcooling $\Delta t_{\text{sub}} = 4$ K				
		Condensing temperature t_c °C				
		+20	+30	+40	+50	+60
EVR 2	0.1	0.43	0.44	0.43	0.40	0.37
	0.2	0.61	0.62	0.61	0.58	0.53
	0.4	0.87	0.87	0.87	0.82	0.75
	0.8	1.19	1.21	1.21	1.19	1.07
	1.6	1.68	1.70	1.69	1.62	1.48
EVR 3	0.1	0.73	0.74	0.73	0.69	0.63
	0.2	1.03	1.04	1.03	0.98	0.89
	0.4	1.46	1.48	1.47	1.39	1.27
	0.8	2.01	2.04	2.03	2.00	1.81
	1.6	2.83	2.87	2.84	2.74	2.50
EVR 6	0.1	2.16	2.18	2.15	2.05	1.86
	0.2	3.03	3.08	3.05	2.90	2.64
	0.4	4.34	4.38	4.35	4.13	3.76
	0.8	5.94	6.05	6.02	5.92	5.37
	1.6	8.37	8.52	8.43	8.10	7.40
EVR 10	0.1	5.1	5.2	5.1	4.9	4.4
	0.2	7.2	7.3	7.3	6.9	6.3
	0.4	10.3	10.4	10.3	9.8	8.9
	0.8	14.1	14.4	14.3	14.1	12.8
	1.6	19.9	20.3	20.0	19.2	17.6
EVR 15	0.1	7.0	7.1	7.0	6.7	6.1
	0.2	9.9	10.0	9.9	9.4	8.6
	0.4	14.1	14.3	14.2	13.4	12.2
	0.8	19.3	19.7	19.6	19.2	17.5
	1.6	27.2	27.7	27.6	26.3	24.1
EVR 20	0.1	13.4	13.7	13.5	12.8	11.6
	0.2	18.9	19.2	19.1	18.2	16.5
	0.4	27.1	27.4	27.2	25.8	23.5
	0.8	37.1	37.8	37.7	37.0	33.6
	1.6	52.4	53.3	52.6	50.6	46.2
EVR 22	0.1	16.1	16.4	16.1	15.4	14.0
	0.2	22.7	23.1	22.9	21.8	19.8
	0.4	32.5	32.9	32.7	31.0	28.2
	0.8	44.5	45.4	45.2	44.4	40.3
	1.6	62.8	64.0	63.2	60.8	55.5
EVR 25	0.1	26.8	27.4	26.9	25.6	23.3
	0.2	37.9	38.4	38.2	36.3	33.0
	0.4	54.2	54.9	54.5	51.7	47.0
	0.8	74.2	75.6	75.3	74.0	67.2
	1.6	105.0	107.0	105.0	101.0	92.5
EVR 32	0.1	43.0	43.8	43.0	40.9	37.3
	0.2	60.6	61.4	61.1	58.1	52.8
	0.4	86.7	87.8	87.2	82.7	75.2
	0.8	119.0	121.0	120.0	118.0	107.0
	1.6	167.0	171.0	168.0	162.0	148.0
EVR 40	0.1	67.0	68.5	67.3	64.0	58.3
	0.2	94.8	96.0	95.5	90.8	82.5
	0.4	136.0	137.0	136.0	129.0	117.0
	0.8	186.0	189.0	188.0	185.0	168.0
	1.6	262.0	266.0	263.0	253.0	231.0

An increase in hot gas temperature t_h of 10 K, based on $t_h = t_e + 25^\circ\text{C}$, reduces valve capacity approx. 2% and vice versa.

A change in evaporating temperature t_e changes valve capacity; see correction factor table below.

Correction factors

When sizing valves, the table value must be multiplied by a correction factor depending on evaporating temperature t_e .

Correction factors for evaporating temperature t_e

t_e °C	-40	-30	-20	-10	0	+10
R440A/R507	0.86	0.88	0.93	1.0	1.03	1.07

Solenoid valves type EVR 2 → 40 – NC / NO New EVR 6 Steel cover design
R407C
Capacity
(continued)

Hot gas capacity Q_h kW

Type	Pressure drop across valve Δp bar	Hot gas capacity Q_h kW				
		Evaporating temp. $t_e = -10^\circ\text{C}$. Hot gas temp. $t_h = t_e + 25^\circ\text{C}$. Subcooling $\Delta t_{\text{sub}} = 4$ K				
		Condensing temperature t_c °C				
		+20	+30	+40	+50	+60
EVR 2	0.1	0.53	0.55	0.57	0.56	0.54
	0.2	0.75	0.78	0.80	0.80	0.76
	0.4	1.08	1.12	1.14	1.14	1.09
	0.8	1.48	1.51	1.58	1.63	1.56
	1.6	2.09	2.19	2.23	2.25	2.15
EVR 3	0.1	0.9	0.94	0.95	0.96	0.91
	0.2	1.28	1.32	1.35	1.35	1.29
	0.4	1.83	1.89	1.93	1.92	1.83
	0.8	2.50	2.54	2.66	2.76	2.63
	1.6	3.53	3.69	3.77	3.79	3.62
EVR 6	0.1	2.7	2.8	2.8	2.8	2.7
	0.2	3.8	4.0	4.0	3.5	3.8
	0.4	5.4	5.6	5.7	5.7	5.5
	0.8	7.4	7.5	7.9	8.2	7.7
	1.6	10.4	10.9	11.1	11.2	10.7
EVR 10	0.1	6.3	6.6	6.7	6.8	6.4
	0.2	9.0	9.4	9.5	9.6	9.1
	0.4	12.8	13.3	13.6	13.5	12.9
	0.8	17.6	17.8	18.7	19.4	18.5
	1.6	24.9	26.0	26.5	26.6	25.5
EVR 15	0.1	8.6	9.0	9.2	9.2	8.7
	0.2	12.3	12.8	12.9	13	12.4
	0.4	17.6	18.3	18.5	18.5	17.6
	0.8	24.1	24.4	25.7	26.5	25.4
	1.6	33.9	35.5	36.3	36.4	34.8
EVR 20	0.1	16.6	17.3	17.7	17.7	16.9
	0.2	23.6	24.5	25.0	25.1	23.9
	0.4	33.6	35.1	35.6	35.7	34.0
	0.8	46.3	47	49.4	51.1	48.6
	1.6	65.3	68.3	69.8	70.1	67.0
EVR 22	0.1	19.9	20.7	21.1	21.2	20.2
	0.2	28.3	29.5	30.0	30.1	28.7
	0.4	40.4	42.1	42.8	42.8	40.8
	0.8	55.4	56.3	59.3	61.3	58.3
	1.6	78.4	82.0	83.7	84	80.4
EVR 25	0.1	33.2	34.5	35.2	35.4	33.7
	0.2	47.2	49.1	50.0	50.1	47.8
	0.4	67.4	70.2	71.3	71.3	68.0
	0.8	92.4	96.7	98.8	102.1	97.2
	1.6	131.0	136.4	139.1	140.4	134.3
EVR 32	0.1	53.1	55.2	56.3	56.6	53.9
	0.2	75.5	78.5	79.9	80.2	76.5
	0.4	107.9	112.2	114.5	114.4	108.8
	0.8	147.8	154.0	158.4	163.3	155.8
	1.6	209.4	218.9	223.6	224.6	214.6
EVR 40	0.1	82.9	86.4	88.1	88.4	84.3
	0.2	117.6	123.2	125.2	125.8	119.6
	0.4	169.1	174.9	178.7	178.9	170.5
	0.8	230.7	244.2	247.2	255.8	243.0
	1.6	325.9	341.0	348.8	350.5	335.2

An increase in hot gas temperature t_h of 10 K, based on $t_h = t_e + 25^\circ\text{C}$, reduces valve capacity approx. 2% and vice versa.

A change in evaporating temperature t_e changes valve capacity; see correction factor table below.

Correction factors

When sizing valves, the table value must be multiplied by a correction factor depending on evaporating temperature t_e .

Correction factors for evaporating temperature t_e

t_e °C	-40	-30	-20	-10	0	+10
R407C	0.90	0.94	0.97	1.0	1.03	1.05

Solenoid valves type EVR 2 → 40 – NC / NO New EVR 6 Steel cover design
**Capacity
(continued)**
Hot gas capacity G_h kg/s
R 22

Type	Hot gas temperature t_h °C	Condensing temperature t_c °C	Hot gas capacity G_h kg/s at pressure drop across valve Δp bar								
			0.5	1	2	3	4	5	6	7	8
EVR 2		+25	0.005	0.007	0.01	0.011	0.012	0.012	0.012	0.012	0.012
		+35	0.006	0.009	0.011	0.013	0.014	0.015	0.015	0.015	0.015
		+45	0.007	0.01	0.013	0.016	0.017	0.018	0.019	0.019	0.02
EVR 3		+25	0.009	0.012	0.016	0.019	0.02	0.02	0.02	0.02	0.02
		+35	0.01	0.014	0.019	0.022	0.024	0.025	0.026	0.026	0.026
		+45	0.012	0.016	0.022	0.026	0.029	0.031	0.032	0.033	0.033
EVR 6		+25	0.027	0.037	0.049	0.055	0.058	0.059	0.059	0.059	0.059
		+35	0.031	0.043	0.057	0.067	0.072	0.075	0.077	0.077	0.077
		+45	0.035	0.049	0.066	0.078	0.086	0.092	0.095	0.097	0.098
EVR 10		+25	0.064	0.088	0.116	0.131	0.139	0.14	0.14	0.14	0.14
		+35	0.074	0.102	0.137	0.158	0.172	0.179	0.182	0.182	0.182
		+45	0.084	0.116	0.158	0.185	0.205	0.218	0.227	0.231	0.232
EVR 15		+25	0.084	0.116	0.153	0.173	0.182	0.184	0.184	0.184	0.184
		+35	0.097	0.134	0.18	0.208	0.226	0.236	0.239	0.239	0.239
		+45	0.11	0.153	0.208	0.244	0.269	0.287	0.298	0.304	0.305
EVR 20		+25	0.169	0.231	0.305	0.346	0.365	0.368	0.368	0.368	0.368
		+35	0.194	0.267	0.359	0.416	0.452	0.472	0.478	0.478	0.478
		+45	0.22	0.305	0.415	0.488	0.539	0.574	0.597	0.608	0.611
EVR 22		+25	0.203	0.277	0.366	0.415	0.438	0.442	0.442	0.442	0.442
		+35	0.279	0.32	0.431	0.499	0.542	0.566	0.574	0.574	0.574
		+45	0.264	0.366	0.498	0.586	0.647	0.689	0.716	0.722	0.733
EVR 25		+25	0.331	0.453	0.599	0.677	0.715	0.722	0.722	0.722	0.722
		+35	0.38	0.524	0.704	0.816	0.886	0.925	0.938	0.938	0.938
		+45	0.431	0.598	0.814	0.956	1.056	1.125	1.169	1.192	1.197
EVR 32		+25	0.539	0.739	0.976	1.106	1.168	1.179			
		+35	0.619	0.856	1.15	1.331	1.446	1.509	1.531		
		+45	0.704	0.978	1.329	1.562	1.723	1.837	1.909	1.947	1.955
EVR 40		+25	0.843	1.155	1.525	1.728	1.825	1.843			
		+35	0.968	1.338	1.798	2.08	2.26	2.358	2.393		
		+45	1.1	1.528	2.078	2.44	2.693	2.87	2.983	3.043	3.055

R134a

Type	Hot gas temperature t_h °C	Condensing temperature t_c °C	Hot gas capacity G_h kg/s at pressure drop across valve Δp bar								
			0.5	1	2	3	4	5	6	7	8
EVR 2		+25	0.005	0.007	0.008	0.008	0.008	0.012	0.012		
		+35	0.006	0.008	0.01	0.011	0.012	0.015	0.015	0.015	0.015
		+45	0.007	0.009	0.012	0.014	0.015	0.015	0.015	0.015	0.015
EVR 3		+25	0.008	0.011	0.011	0.014	0.014	0.018	0.018		
		+35	0.009	0.013	0.016	0.018	0.018	0.018	0.018	0.025	0.025
		+45	0.01	0.016	0.02	0.023	0.025	0.025	0.025	0.025	0.025
EVR 6		+25	0.024	0.032	0.04	0.041	0.041	0.056	0.056		
		+35	0.028	0.038	0.049	0.055	0.056	0.056	0.056	0.073	0.073
		+45	0.032	0.045	0.059	0.068	0.072	0.073	0.073	0.073	0.073
EVR 10		+25	0.057	0.075	0.094	0.098	0.098	0.132	0.132		
		+35	0.066	0.09	0.117	0.13	0.132	0.132	0.132	0.172	0.172
		+45	0.076	0.107	0.141	0.161	0.17	0.172	0.172	0.172	0.172
EVR 15		+25	0.074	0.1	0.124	0.129	0.129	0.167	0.167		
		+35	0.087	0.119	0.154	0.171	0.167	0.167	0.167	0.225	0.225
		+45	0.1	0.14	0.185	0.212	0.223	0.225	0.225	0.225	0.225
EVR 20		+25	0.149	0.199	0.247	0.258	0.258	0.347	0.347		
		+35	0.174	0.238	0.307	0.341	0.347	0.347	0.347	0.452	0.452
		+45	0.2	0.28	0.37	0.423	0.447	0.452	0.452	0.452	0.452
EVR 22		+25	0.179	0.239	0.296	0.31	0.31	0.416	0.416		
		+35	0.209	0.286	0.368	0.409	0.416	0.416	0.416	0.542	0.542
		+45	0.24	0.336	0.444	0.508	0.536	0.542	0.542	0.542	0.542
EVR 25		+25	0.292	0.391	0.486	0.506	0.506	0.679	0.679		
		+35	0.341	0.467	0.602	0.668	0.679	0.679	0.679	0.885	0.885
		+45	0.393	0.549	0.725	0.83	0.876	0.885	0.885	0.885	0.885
EVR 32		+25	0.478	0.638	0.793	0.826	0.826	1.108	1.108		
		+35	0.556	0.763	0.994	1.091	1.108	1.108	1.108	1.446	1.446
		+45	0.641	0.897	1.197	1.354	1.432	1.446	1.446	1.446	1.446
EVR 40		+25	0.747	0.998	1.24	1.291	1.291	1.731	1.731		
		+35	0.87	1.192	1.553	1.704	1.731	1.731	1.731	2.259	2.259
		+45	1.002	1.402	1.87	2.117	2.237	2.259	2.259	2.259	2.259

An increase in hot gas temperature t_h of 10 K reduces valve capacity approx. 2% and vice versa.

Solenoid valves type EVR 2 → 40 – NC / NO New EVR 6 Steel cover design

Capacity
(continued)

Hot gas capacity G_h kg/s

R404A/R507

Type	Hot gas temperature t_h °C	Condensing temperature t_c °C	Hot gas capacity G_h kg/s at pressure drop across valve Δp bar								
			0.5	1	2	3	4	5	6	7	8
EVR 2	+60	+25	0.007	0.009	0.012	0.014	0.016	0.016	0.016	0.016	0.016
		+35	0.008	0.011	0.014	0.017	0.019	0.02	0.02	0.02	0.02
		+45	0.009	0.012	0.016	0.019	0.021	0.024	0.025	0.025	0.025
EVR 3		+25	0.011	0.016	0.021	0.024	0.026	0.026	0.027	0.027	0.027
		+35	0.013	0.018	0.024	0.029	0.031	0.033	0.035	0.035	0.035
		+45	0.015	0.02	0.028	0.032	0.037	0.039	0.041	0.043	0.043
EVR 6		+25	0.034	0.047	0.062	0.072	0.077	0.079	0.08	0.08	0.08
		+35	0.038	0.054	0.072	0.085	0.093	0.098	0.101	0.101	0.102
		+45	0.043	0.061	0.082	0.097	0.108	0.116	0.122	0.126	0.128
EVR 10	+25	0.08	0.11	0.148	0.17	0.183	0.188	0.19	0.19	0.19	
	+35	0.091	0.127	0.171	0.2	0.22	0.233	0.241	0.241	0.243	
	+45	0.102	0.143	0.194	0.23	0.257	0.277	0.288	0.3	0.303	
EVR 15	+25	0.105	0.146	0.195	0.224	0.24	0.247	0.249	0.249	0.249	
	+35	0.12	0.167	0.224	0.253	0.289	0.307	0.316	0.317	0.32	
	+45	0.135	0.189	0.225	0.303	0.339	0.365	0.38	0.393	0.399	
EVR 20	+25	0.21	0.29	0.39	0.448	0.48	0.495	0.5	0.5	0.5	
	+35	0.239	0.333	0.45	0.526	0.58	0.614	0.632	0.633	0.639	
	+45	0.27	0.375	0.51	0.606	0.677	0.729	0.76	0.785	0.799	
EVR 22	+25	0.252	0.348	0.468	0.538	0.576	0.594	0.6	0.6	0.6	
	+35	0.287	0.4	0.54	0.631	0.696	0.737	0.758	0.76	0.767	
	+45	0.324	0.45	0.612	0.727	0.812	0.875	0.912	0.942	0.959	
EVR 25	+25	0.411	0.57	0.763	0.878	0.942	0.969	0.978	0.978	0.978	
	+35	0.468	0.653	0.881	1.032	1.136	1.203	1.239	1.241	1.253	
	+45	0.529	0.734	1.0	1.188	1.326	1.43	1.49	1.539	1.566	
EVR 32	+25	0.672	0.931	1.245	1.432	1.539	1.581	1.581	1.581	1.581	
	+35	0.765	1.069	1.436	1.686	1.854	1.964	2.022	2.025	2.025	
	+45	0.862	1.198	1.632	1.939	2.16	2.34	2.433	2.513	2.557	
EVR 40	+25	1.05	1.454	1.946	2.238	2.406	2.471	2.471	2.471	2.471	
	+35	1.195	1.657	2.245	2.635	2.897	3.068	3.161	3.166	3.166	
	+45	1.348	1.873	2.55	3.03	3.384	3.65	3.801	3.926	3.995	

R407C

Type	Hot gas temperature t_h °C	Condensing temperature t_c °C	Hot gas capacity G_h kg/s at pressure drop across valve Δp bar								
			0.5	1	2	3	4	5	6	7	8
EVR 2	+90	+25	0.0054	0.0076	0.0108	0.0118	0.0130	0.0132	0.0132	0.0132	0.0132
		+35	0.0065	0.0097	0.0118	0.0140	0.0151	0.0165	0.0165	0.0165	0.0165
		+45	0.0076	0.0108	0.0140	0.0173	0.0184	0.0198	0.0209	0.0209	0.022
EVR 3		+25	0.010	0.013	0.017	0.021	0.022	0.022	0.022	0.022	0.022
		+35	0.011	0.015	0.021	0.024	0.026	0.028	0.029	0.029	0.029
		+45	0.013	0.017	0.024	0.028	0.032	0.034	0.036	0.037	0.037
EVR 6		+25	0.029	0.040	0.053	0.06	0.063	0.065	0.065	0.065	0.065
		+35	0.033	0.046	0.062	0.073	0.078	0.083	0.085	0.085	0.085
		+45	0.038	0.053	0.071	0.085	0.094	0.101	0.105	0.108	0.109
EVR 10	+25	0.069	0.095	0.125	0.143	0.152	0.154	0.155	0.155	0.155	
	+35	0.08	0.11	0.148	0.172	0.187	0.197	0.202	0.202	0.202	
	+45	0.091	0.125	0.171	0.202	0.223	0.24	0.252	0.256	0.258	
EVR 15	+25	0.091	0.125	0.165	0.189	0.198	0.202	0.204	0.204	0.204	
	+35	0.105	0.145	0.194	0.227	0.246	0.26	0.265	0.265	0.265	
	+45	0.119	0.165	0.225	0.266	0.293	0.316	0.331	0.337	0.339	
EVR 20	+25	0.183	0.249	0.329	0.377	0.398	0.405	0.408	0.408	0.408	
	+35	0.21	0.288	0.388	0.453	0.493	0.519	0.531	0.531	0.531	
	+45	0.238	0.329	0.448	0.532	0.588	0.631	0.663	0.675	0.678	
EVR 22	+25	0.219	0.299	0.395	0.452	0.477	0.486	0.491	0.491	0.491	
	+35	0.301	0.346	0.465	0.544	0.591	0.623	0.637	0.637	0.637	
	+45	0.285	0.395	0.538	0.639	0.705	0.758	0.795	0.801	0.814	
EVR 25	+25	0.357	0.489	0.647	0.738	0.779	0.794	0.801	0.801	0.801	
	+35	0.41	0.566	0.76	0.889	0.966	1.018	1.041	1.041	1.041	
	+45	0.465	0.646	0.879	1.042	1.151	1.238	1.298	1.323	1.329	
EVR 32	+25	0.582	0.798	1.054	1.206	1.273	1.297				
	+35	0.669	0.924	1.242	1.451	1.576	1.66	1.699			
	+45	0.76	1.056	1.435	1.703	1.878	2.021	2.119	2.161	2.17	
EVR 40	+25	0.91	1.247	1.647	1.884	1.989	2.027				
	+35	1.045	1.445	1.942	2.267	2.463	2.594	2.656			
	+45	1.188	1.65	2.244	2.66	2.935	3.157	3.311	3.378	3.391	

An increase in hot gas temperature t_h of 10 K reduces valve capacity approx. 2% and vice versa.

Design / Function

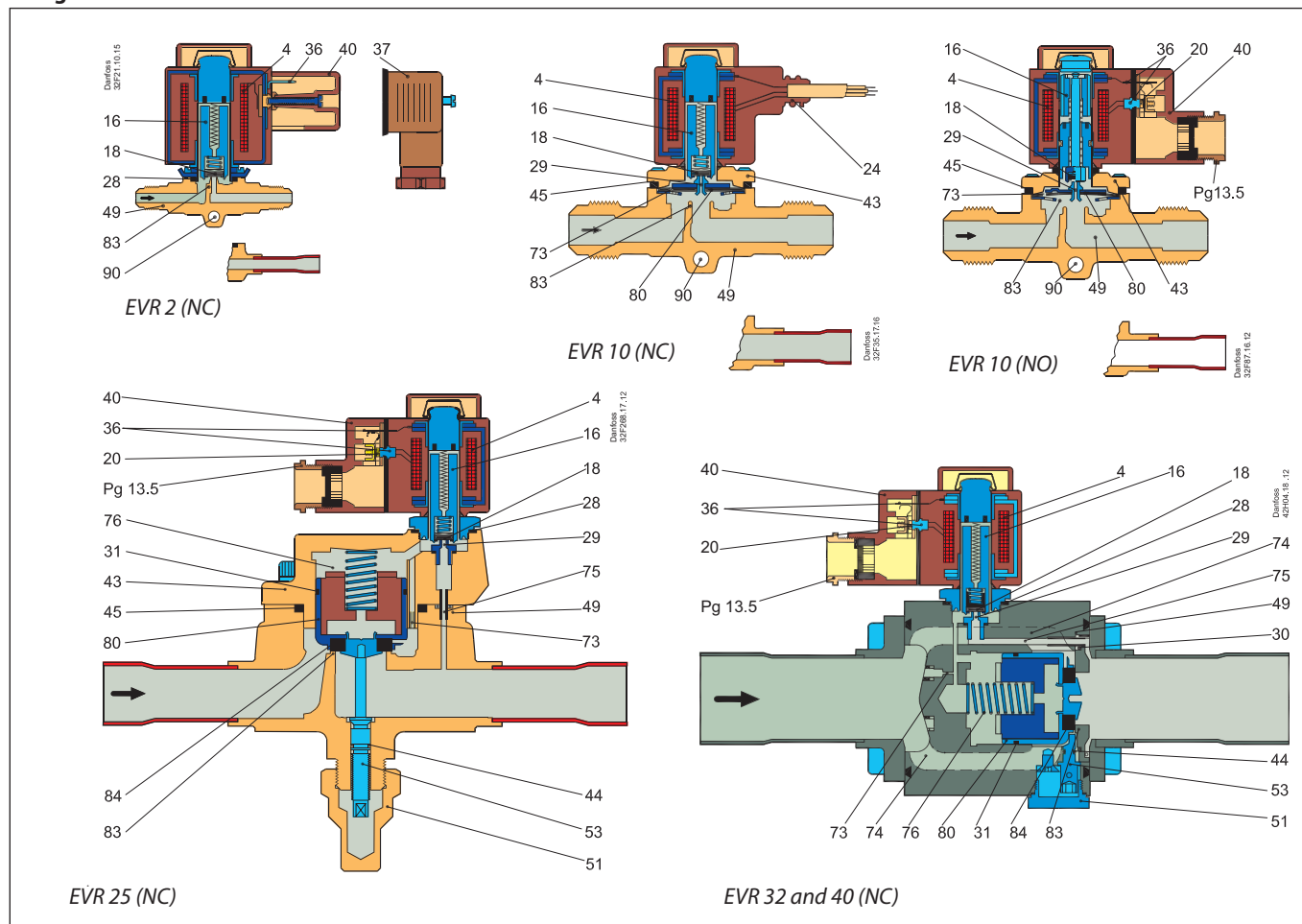

- 4. Coil
- 16. Armature
- 18. Valve plate / Pilot valve plate
- 20. Earth terminal
- 24. Connection for flexible steel hose
- 28. Gasket
- 29. Pilot orifice
- 30. O-ring
- 31. Piston ring
- 36. DIN plug
- 37. DIN socket (to DIN 43650)
- 40. Protective cap/Terminal box
- 43. Valve cover
- 44. O-ring
- 45. Valve cover gasket
- 49. Valve body
- 50. Gasket
- 51. Threaded plug
- 53. Manual operation spindle
- 73. Equalization hole
- 74. Main channel
- 75. Pilot channel
- 76. Compression spring
- 80. Diaphragm/Servo piston
- 83. Valve seat
- 84. Main valve plate
- 90. Mounting hole

EVR solenoid valves are designed on two different principles:

1. Direct operation
2. Servo operation

1. Direct operation

EVR 2 and 3 are direct operated. The valves open direct for full flow when the armature (16) moves up into the magnetic field of the coil.

This means that the valves operate with a min. differential pressure of 0 bar.

The teflon valve plate (18) is fitted direct on the armature (16).

Inlet pressure acts from above on the armature and the valve plate. Thus, inlet pressure, spring force and the weight of the armature act to close the valve when the coil is currentless.

2. Servo operation

EVR 6 → 22 are servo operated with a "floating" diaphragm (80). The pilot orifice (29) of stainless steel is placed in the centre of the diaphragm.

The teflon pilot valve plate (18) is fitted direct to the armature (16). When the coil is currentless, the main orifice and pilot orifice are closed. The pilot orifice and main orifice are held closed by the weight of the armature, the armature spring force and the differential pressure between inlet and outlet sides.

When current is applied to the coil the armature is drawn up into the magnetic field and opens the pilot orifice. This relieves the pressure above the diaphragm, i.e. the space above the diaphragm becomes connected to the outlet side of the valve.

The differential pressure between inlet and outlet sides then presses the diaphragm away from the main orifice and opens it for full flow. Therefore a certain minimum differential pressure is necessary to open the valve and keep it open. For EVR 6 → 22 valves this differential pressure is 0.05 bar. When current is switched off, the pilot orifice closes. Via the equalization holes (73) in the diaphragm, the pressure above the diaphragm then rises to the same value as the inlet pressure and the diaphragm closes the main orifice.

EVR 25, 32 and 40 are servo operated piston valves. The valves are closed with currentless coil. The servo piston (80) with main valve plate (84) closes against the valve seat (83) by means of the differential pressure between inlet and outlet side of the valve, the force of the compression spring (76) and possibly the piston weight. When current to the coil is switched on, the pilot orifice (29) opens. This relieves the pressure on the piston spring side of the valve. The differential pressure will then open the valve. The minimum differential pressure needed for full opening of the valves is 0.2 bar. EVR (NO) has the opposite function to EVR (NC), i.e. it is open with de-energised coil.

EVR (NO) is available with servo operation only.

Solenoid valves type EVR 2 → 40 – NC / NO New EVR 6 Steel cover design

Material specifications

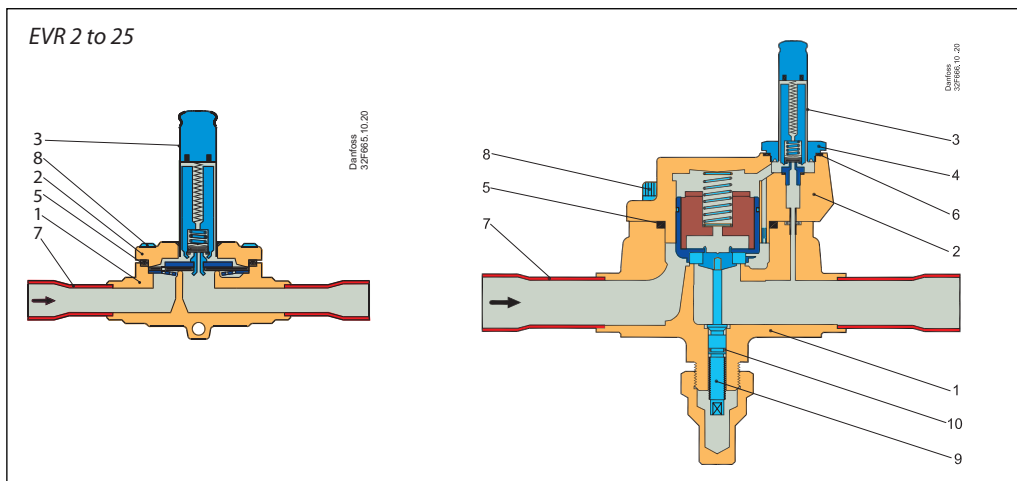

		Solenoid valves					Standard	
No.	Description	Type	Material	Analysis	Mat.no.	W.no.	DIN	EN
1	Valve body	EVR 2 to 25	Brass	CuZn40Pb2	CW617N	2.0402	17672-1	12165
2	Cover	EVR 2 to 6	Stainless steel	X5 CrNi18-10		1.4301		10088
		EVR 10 to 22	Brass	CuZn40Pb2	CW617N	2.0402	17672-1	12165
		EVR 25	Cast iron	EN-GJS-400-18-LT	EN-JS1025			1563
3	Armature tube	EVR 2 to 25	Stainless steel	X2 CrNi19-11		1.4306		10088
4	Armature tube nut	EVR 25	Stainless steel	X8 CrNiS 18-9		1.4305		10088
5	Gasket	EVR 2 to 25	Rubber	Cr				
6	Gasket	EVR 25	Al. gasket	Al 99.5		3.0255		10210
7	Solder tube	EVR 25	Copper	SF-Cu	CW024A	2.0090	1787	12449
8	Screws	EVR 2 to 25	Stainless steel	A2-70			3506	
9	Spindle for man. operat.	EVR 25	Stainless steel	X8 CrNiS 18-9		1.4305		10088
10	Gasket	EVR 25	Rubber	Cr				

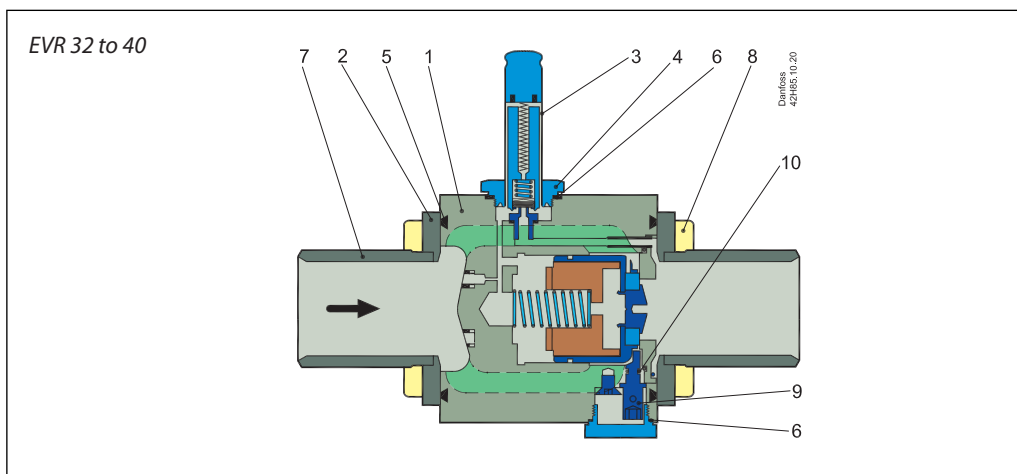

		Solenoid valves					Standard	
No.	Description	Type	Material	Analysis	Mat.no.	W.no.	DIN	EN
1	Valve body	EVR 32/40	Cast Iron	EN-GJS-400-18-LT	EN-JS1025			1563
2	Cover	EVR 32/40	Brass	CuZn40Pb2	CW617N	2.0402		12165
3	Armature tube	EVR 32/40	Stainless steel	X2 CrNi19-11		1.4306		10088
4	Armature tube nut	EVR 32/40	Stainless steel	X8 CrNiS 18-9		1.4305		10088
5	Gasket	EVR 32/40	Rubber	Cr				
6	Gasket	EVR 32/40	Al. gasket	Al 99.5		3.0255		10210
7	Solder tube	EVR 32/40	Copper	SF.Cu	CW024A	2.0090	1787	12449
8	Screws	EVR 32/40	Stainless steel	A2-70			3506	
9	Spindle for man. operation	EVR 32/40	Stainless steel	X8 CrNiS 18-9		1.4305		10088

Solenoid valves type EVR 2 → 40 – NC / NO New EVR 6 Steel cover design

Dimensions and weights

EVR (NC) 2 → 15 and EVR 6 → 15 (NO), flare connection

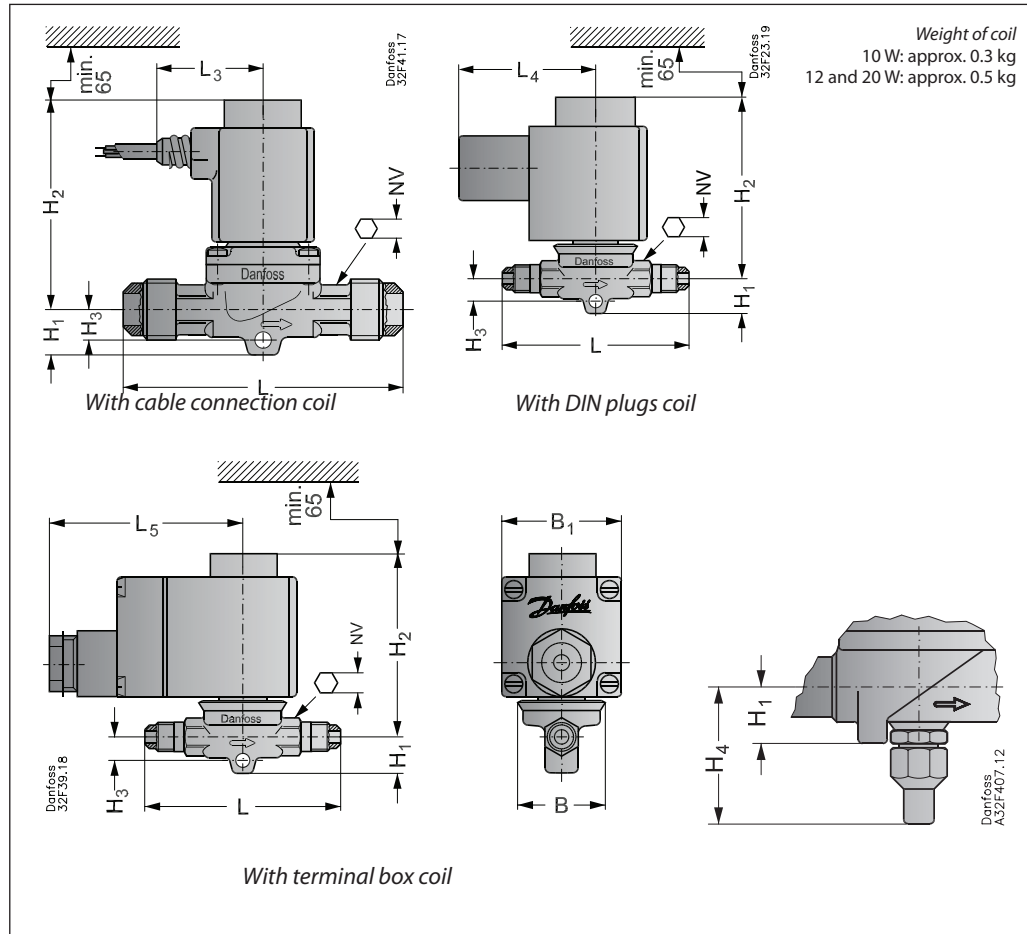

Type	Connection Flare		H ₁	H ₂	H ₃	H ₄	L	L ₂	L ₃	L ₄	NV	L ₅ max.		B	B ₁ max.	Weight with coil
	in.	mm										10 W	12/20 W			
EVR 2	1/4	6	14	73	9		75		45	54	13	75	85	33	68	0.5
EVR 3	1/4	6	14	73	9		75		45	54	13	75	85	33	68	0.5
	3/8	10	14	73	9		75		45	54	13	75	85	33	68	0.5
EVR 6	3/8	10	14	78	10		82		45	54	14	75	85	33	68	0.6
	1/2	12	14	78	10		88		45	54	14	75	85	33	68	0.6
EVR 10	1/2	12	16	79	11		103		45	54	16	75	85	46	68	0.8
	5/8	16	16	79	11		110		45	54	16	75	85	46	68	0.8
EVR 15	5/8	16	19	86		49	131		45	54	24	75	85	56	68	1.0

Solenoid valves type EVR 2 → 40 – NC / NO New EVR 6 Steel cover design

Dimensions and weights (continued)

EVR (NC) 2 → 22 and EVR 6 → 22 (NO), solder connection

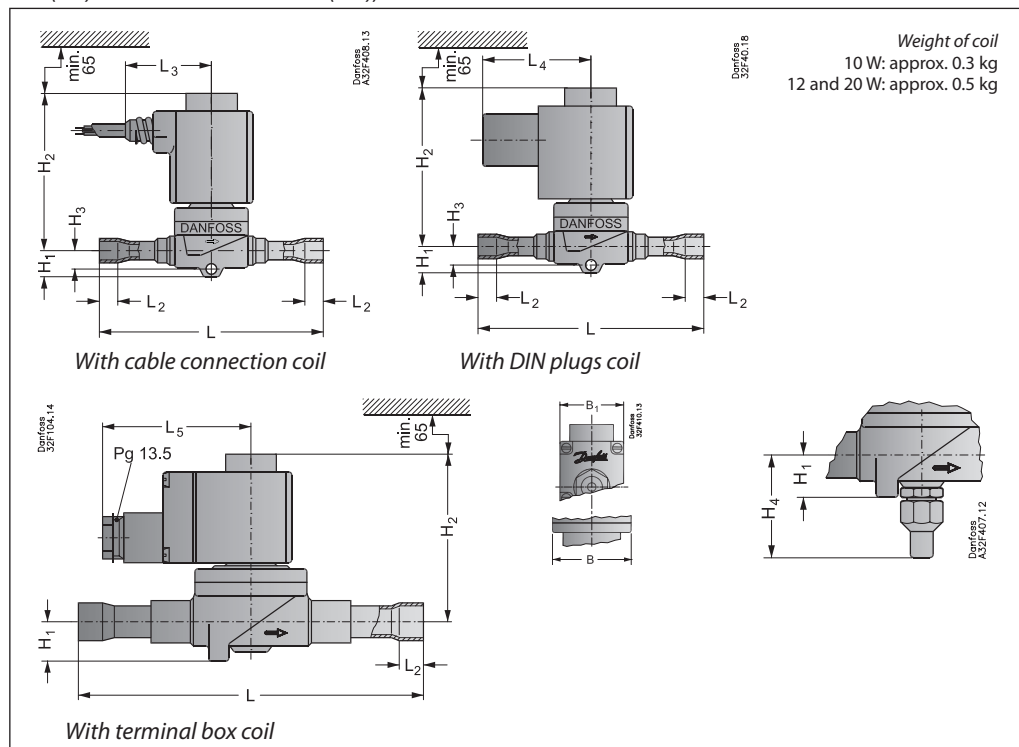

Type	Connection Solder		H ₁	H ₂	H ₃	H ₄	L	L ₂	L ₃	L ₄	L ₅ max.		B	B ₁ max.	Weight with coil
	in.	mm									10 W	12/20 W			
EVR 2	1/4	6	14	73	9		102	7	45	54	75	85	33	68	0.5
EVR 3	1/4	6	14	73	9		102	7	45	54	75	85	33	68	0.6
	3/8	10	14	73	9		117	9	45	54	75	85	33	68	0.6
EVR 6	3/8	10	14	78	10		111	9	45	54	75	85	33	68	0.6
	1/2	12	14	78	10		127	10	45	54	75	85	33	68	0.6
EVR 10	1/2	12	16	79	11		127	10	45	54	75	85	46	68	0.7
	5/8	16	16	79	11		160	12	45	54	75	85	46	68	0.7
EVR 15	5/8	16	19	86		49	176	12	45	54	75	85	56	68	1.0
	7/8	22	19	86			176	17	45	54	75	85	56	68	1.0
EVR 20	7/8	22	20	90		53	191	17	45	54	75	85	72	68	1.5
	1 1/8	28	20	90			214	22	45	54	75	85	72	68	1.5
EVR 22	1 3/8	35	20	90			281	25	45	54	75	85	72	68	1.5

Solenoid valves type EVR 2 → 40 – NC / NO New EVR 6 Steel cover design

Dimensions and weights (continued)

EVR (NC) 25, 32 og 40, solder connection

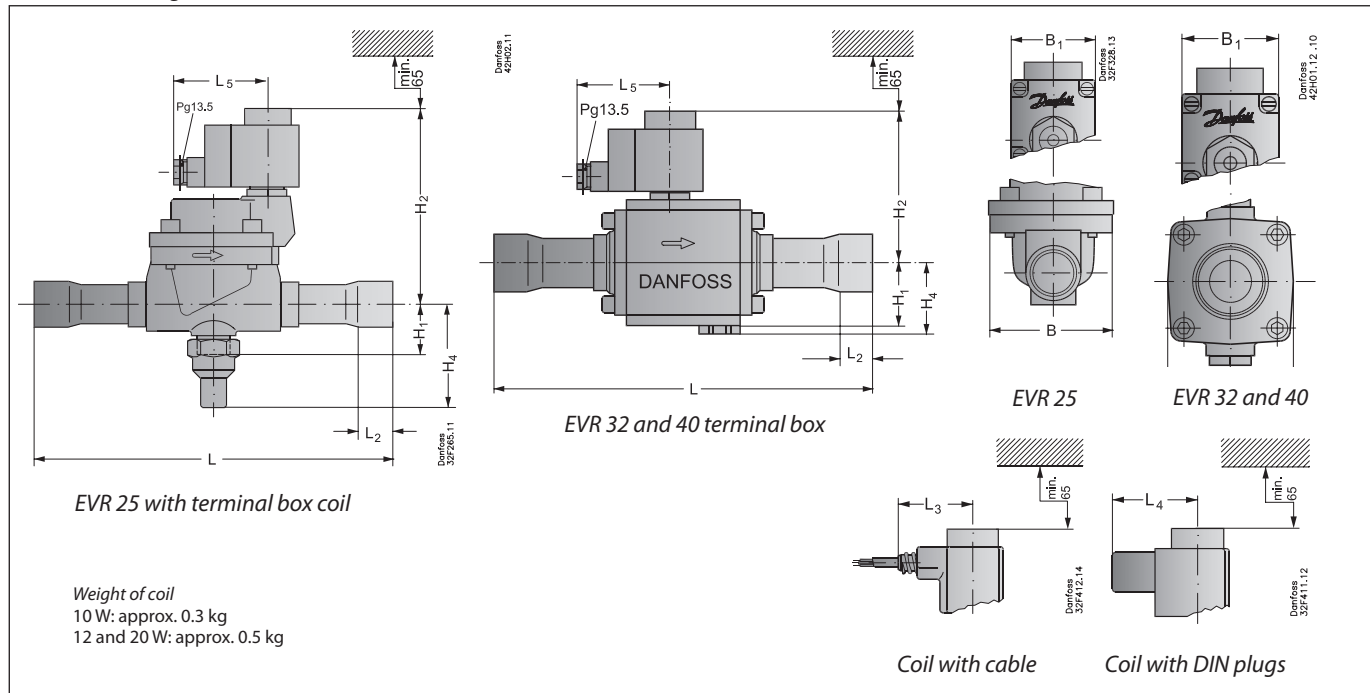

Type	Connection Solder		H ₁	H ₂	H ₃	H ₄	L	L ₂	Coil with cable connection L ₃	Coil with DIN connection L ₄	Coil with terminal box L ₅ max.		B	B ₁ max.	Weight with coil
	in.	mm									10 W	12/20 W			
EVR 25	1 1/8	28	38	138		72	256	22	45	54	75	85	95	68	3.0
	1 3/8	35	38	138		72	281	25	45	54	75	85	95	68	3.3
EVR 32	1 3/8	35	47	111		53	281	25	45	54	75	85	80	68	4.5
	1 5/8	42	47	111		53	281	29	45	54	75	85	80	68	4.6
EVR 40	1 5/8	42	47	111		53	281	29	45	54	75	85	80	68	4.6
	2 1/8	54	47	111		53	281	34	45	54	75	85	80	68	4.6

EVR (NC) 15 and 20, flange connection

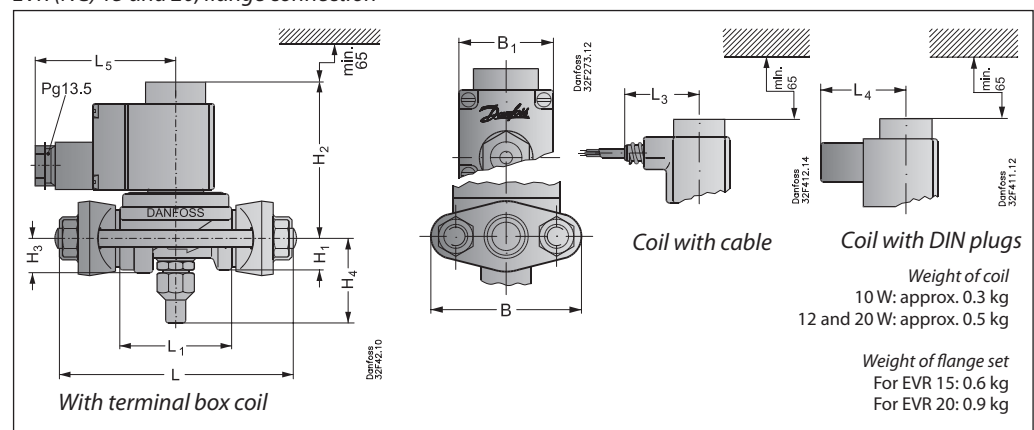

Type	H ₁	H ₂	H ₃	H ₄	L	L ₁	L ₂	Coil with cable connection L ₃	Coil with DIN connection L ₄	Coil with terminal box L ₅ max.		B	B ₁ max.	Weight with coil excl. flanges
										10 W	12/20 W			
EVR 15	19	86	19	49	125	68		45	54	75	85	80	68	1.2
EVR 20	20	90	21	53	155	85		45	54	75	85	96	68	1.7